

Stafsjö
SINCE 1666

Knife gate valve HL

Compact through-going knife gate valve

Size range:
DN 400 - DN 800 (16" - 32")



About HL

This is a compact through-going knife gate valve with superior flow characteristics, offering reliable bi-directional zero leakage shut-off on highly concentrated media and static media columns.

The HL knife gate valve is modular designed and it can easily be customized in materials, with actuators and related automation accessories to different process conditions. It can operate on different media such as pulp stock up to 18% concentrations, slurry, liquor, ash and granulate. The valve has a two-piece precision machined valve body in stainless steel with a high strength top works that provide an essential and precise gate alignment.

The HL knife gate valve is one out of five of Stafsjö's through-going knife gate valves. The HG represent standard. HP is a high pressure version of HG and the HPT is a high pressure version entirely made in Titanium. Finally, the HX is an extreme high pressure version.



Full bore with outstanding flow characteristics

When the HL knife gate valve is in open position, it offers an unobstructed flow path where no media can collect. The PTFE seats (1) are protected by the gate (2) and retainer rings (3) and the internal back-up o-rings (4) keep the seats constantly pressurized against the gate.

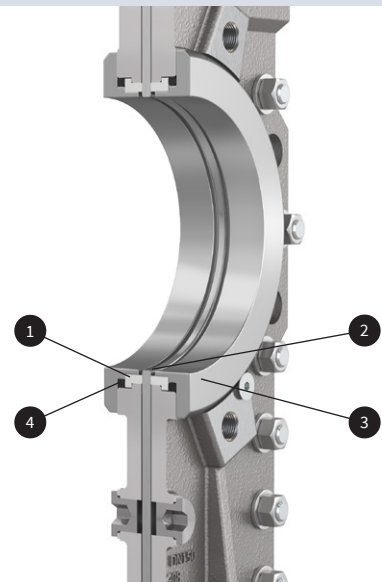

Reliable through-going and bi-directional zero leakage shut-off

The gate is guided throughout the entire stroke and operates smoothly through difficult and highly concentrated media. The retainer ring system (5) on both side of the gate provide a tight seal independent of pressure direction and the gland box sealing system with three layers of Stafsjö's TwinPack (6) ensures that no media reaches surrounding environment.

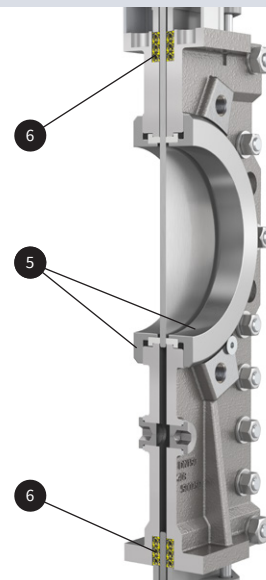

Extended service life with the retainer ring system

The retainer rings (7) hold the seats (8) and the back-up o-rings (9) in exact correct position as the gate strokes. They are mechanically locked and can easily be removed for seat change, thus reducing downtime for the maintenance.

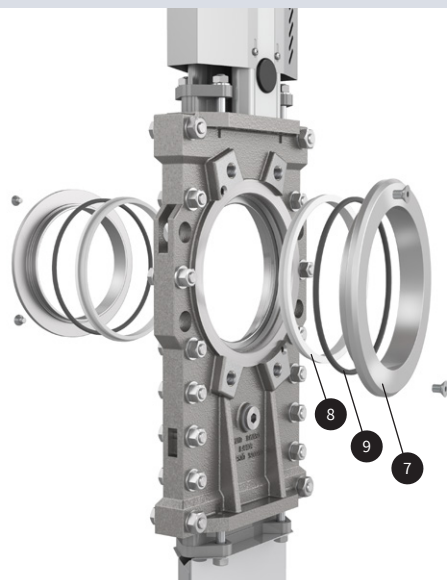

Pressure class

Max working pressure at 20 °C		Max differential pressure at 20 °C	
DN	bar	DN	bar
400	6	400	6
500 - 800	4	500 - 800	4

Configurations

Standard in stainless steel

Sizes: DN 400 - DN 800

Valve body: Stainless steel EN 1.4408

Retainer rings: Stainless steel EN 1.4408

Gate: Stainless steel EN 1.4404, AISI 316L

Box packing: TwinPack

Top works: Stainless steel tie rods encapsulated in aluminum beams including stainless steel gate guards on automated valves

Options

Valve body¹⁾

Stainless steel EN 1.4408

Retainer rings

Stainless steel EN 1.4408

Gate material and surface treatments

Stainless steel EN 1.4404, AISI 316L

Duplex stainless steel EN 1.4462, S32205

Hard chromed surface

Extra polished surface (max Ra 0,8)

Seats

PTFE with o-ring in NBR or FPM/FKM

Box packings

TwinPack or WhitePack

Top works

Stainless steel tie rods encapsulated in aluminum beams

Stainless steel pillars or beams

Actuators

Hand wheel with non-rising stem

Bevel gear

Double-acting pneumatic cylinder

Single-acting pneumatic cylinder

Electric actuator

Hydraulic actuator

Flange drillings

EN 1092 PN 10

EN 1092 PN 16

ASME/ANSI B16.5 and B16.47 Class 150, series A

JIS B 2238 10K

AS 2129 Table D and E

BS 10 Table D

Accessories

Limit switches, solenoid valves, positioners, mechanical lockouts. See Stafsjö's accessory data sheet for further information.

Design standards

Design, manufacturing, inspection and test

According to pressure equipment directive 2014/68/EU category I and II module A2. The valves are CE marked when it is applicable.

Stafsjö's valves are subject for pressure tests before delivery in opened and closed position with water at 20 °C according to EN 12266-1:2003 rate A. No visually detectable leakage is allowed for duration of the test.

On request Stafsjö can provide 2.2 test report and 3.1 inspection certificate according to EN 10204.

Contact Stafsjö for further information on ATEX approved solutions.

Face-to-face dimensions

Stafsjö manufacturing standard.

Service temperature

Information to determine minimum and maximum temperature for the knife gate valve is available on stafsjo.com/support/temperatures/.

1) The valve body is as standard supplied with G1/2" purge ports.

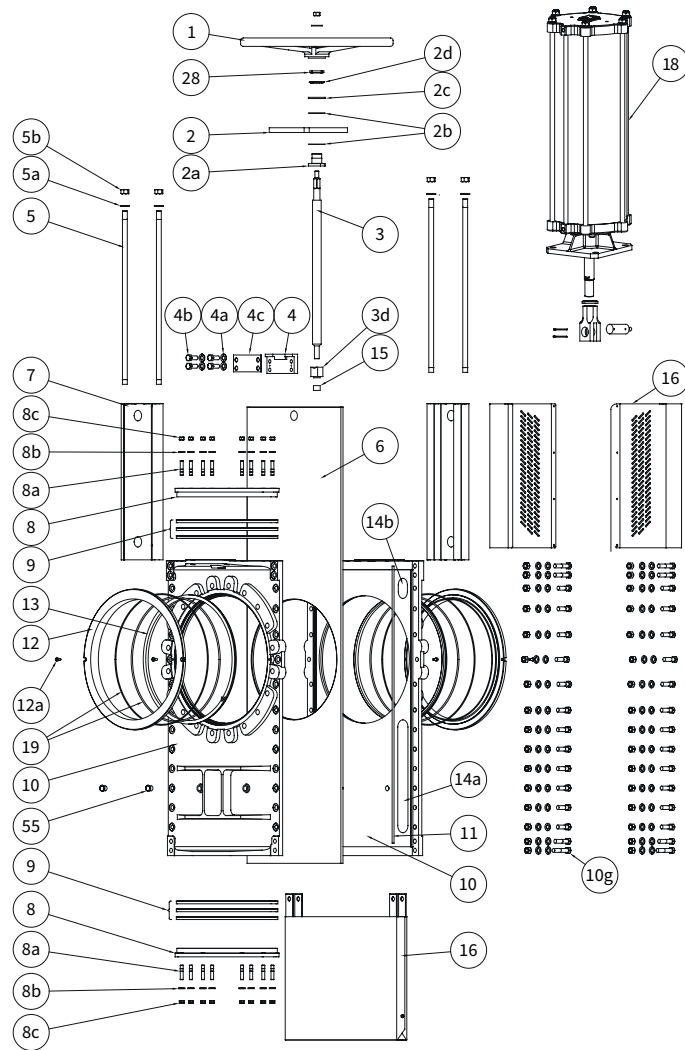

Part list

Pos.	Detail	Material
1	Hand wheel	Coated cast iron EN-JL1030, GG20
2	Yoke	Stainless steel EN 1.4301
2a	Bearing	Brass
2b	Slide washer	POM
2c	Bearing	Brass
2d	Locking washer	Stainless steel EN 1.4301
3	Stem	Stainless steel EN 1.4305
3d	Gate stopper	Brass
4	Stem nut	Brass
4a	Washer	Stainless steel A2
4b	Screw	Stainless steel A2
4c	Distance plate	Stainless steel EN 1.4301
5	Tie rod	Stainless steel A2
5a	Washer	Stainless steel A2
5b	Nut	Stainless steel A2
6	Gate	See options on page 3
7	Beam	Anodized aluminum
8	Gland	Stainless steel EN 1.4408
8a	Stud bolt	Stainless steel A2

Pos.	Detail	Material
8b	Washer	Stainless steel A2
8c	Nut	Stainless steel A2
9 ⁴⁾	Box packing	See options on page 3
10	Valve body	Stainless steel EN 1.4408
10d	Screw	Stainless steel A2
10e	Washer	Stainless steel A2
10f	Nut	Stainless steel A2
11	Body gasket	FPM/FKM
12	Retainer ring	Stainless steel EN 1.4408
12a	Locking screw	Stainless steel A4
13 ⁴⁾	Seat	PTFE with o-ring NBR or FPM/FKM
14a	Guide strip	PTFE
14b	Guide strip	PTFE
15	Bushing	Oil bronze
16	Gate guards	Stainless steel EN 1.4301
18	Cylinder	See data sheet
19 ⁴⁾	O-ring	See options on page 3
55	Plug	Stainless steel A4

⁴⁾ Recommended spare parts

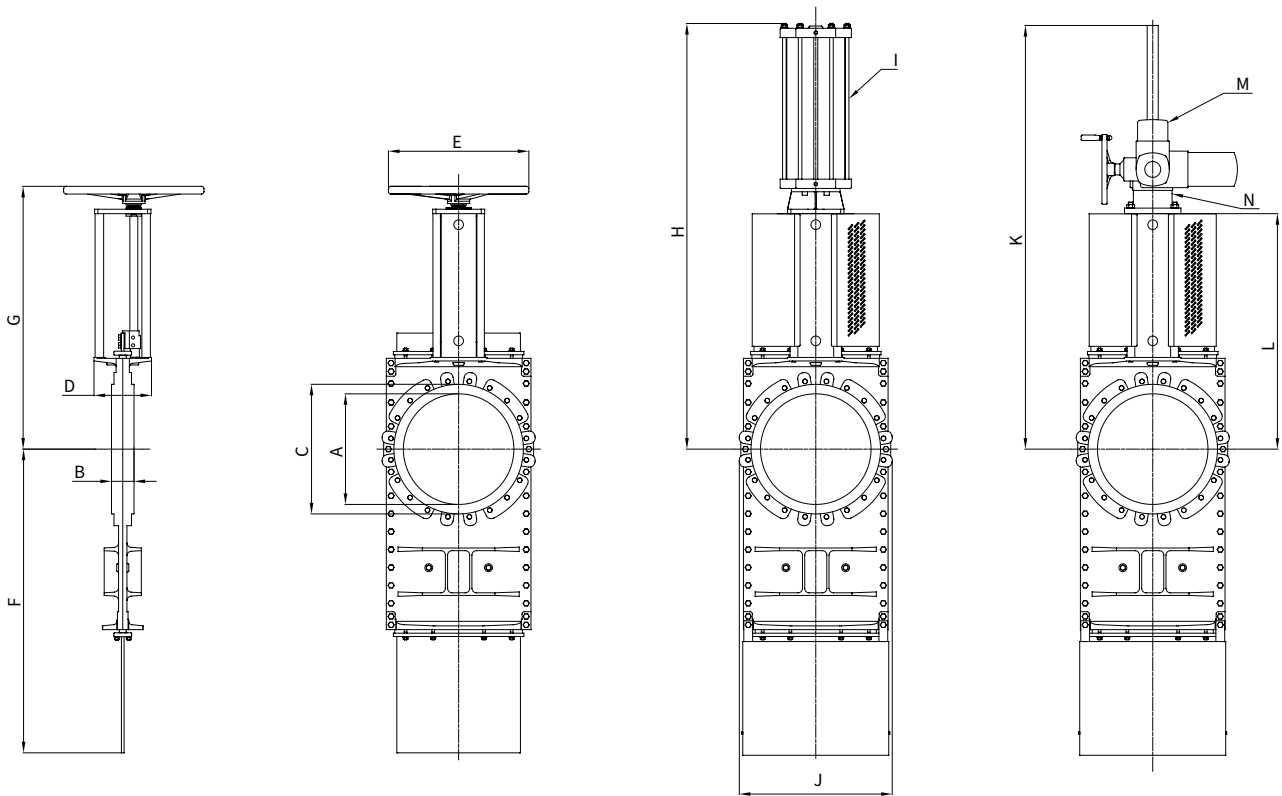

Main dimensions (mm)

DN	A	B	C	D	F	G	H	I	J	K	L	M	N
400	400	84	481	181	1107	980	*	200	571	1423	876	SA 10.2	F10/A
500	500	101	586	260	1384	1188	1950	SC250	693	1768	1065	SA 14.2	F14/A
600	600	106	685	260	1655	1356	2222	SC250	821	2035	1232	SA 14.2	F14/A
800	800	128	901	310	2171	1701	2775	SC320	1041	2585	1582	SA 14.6	F14/A

* Available on request

Main dimensions are only for information. Contact Stafsjö for certified drawings.

Flange drilling according to EN 1092 PN 10

DN	400	500	600	800
Bolt circle diameter (mm)	515	620	725	950
Number of throughgoing bolts	4	-	-	4
Number of tapped holes/side	12	20	20	20
Bolt size	M24	M24	M27	M30
Bolt lengths ¹⁾ (mm)	24	29	29	38

Flange drilling according to EN 1092 PN 16

DN	400	500	600	800
Bolt circle diameter (mm)	525	650	770	950
Number of throughgoing bolts	4	4	4	4
Number of tapped holes/side	12	16	16	20
Bolt size	M27	M30	M33	M36
Bolt lengths ¹⁾ (mm)	24	29	29	38

Flange drilling according to ASME/ANSI B 16.5 and 16.47 Class 150 series A

DN	400	500	600	800
Bolt circle diameter (mm)	540	635	749	978
Number of throughgoing bolts	4	4	4	4
Number of tapped holes/side	12	16	16	24
Bolt size (UNC)	1"	1 1/8"	1 1/4"	1 1/2"
Bolt lengths ¹⁾ (mm)	24	29	29	38

Flange drilling according to BS Table D

DN	400	500	600	800
Bolt circle diameter (mm)	520,7	641,4	755,7	984,2
Number of throughgoing bolts	-	4	4	4
Number of tapped holes/side	12	12	12	16
Bolt size (UNC)	7/8"	7/8"	1"	1 1/4"
Bolt lengths ¹⁾ (mm)	24	29	29	38

Flange drilling according to AS 2129 Table D

DN	400	500	600	800
Bolt circle diameter (mm)	521	641	756	984
Number of throughgoing bolts	-	4	4	4
Number of tapped holes/side	12	12	12	16
Bolt size	M24	M24	M27	M33
Bolt lengths ¹⁾ (mm)	24	29	29	38

1) Add the values with the thickness of flanges, washers and gaskets.

Flange drilling according to AS 2129 Table E

DN	400	500	600	800
Bolt circle diameter (mm)	521	641	756	984
Number of throughgoing bolts	-	4	4	4
Number of tapped holes/side	12	12	12	16
Bolt size	M24	M24	M30	M33
Bolt lengths ¹⁾ (mm)	24	29	29	38

Flange drilling according to JIS B 2238 10K

DN	400	500	600	800
Bolt circle diameter (mm)	510	620	730	950
Number of throughgoing bolts	-	-	-	4
Number of tapped holes/side	16	20	24	24
Bolt size	M24	M24	M30	M30
Bolt lengths ¹⁾ (mm)	24	29	29	38

1) Add the values with the thickness of flanges, washers and gaskets.

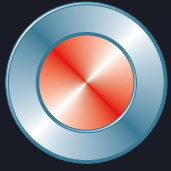

Stafsjö
SINCE 1666

© Stafsjö 2023. Data is only for informational purpose. All specifications are subject to change without notice.

Stafsjö Valves AB
SE-618 95 Stavsjö, Sweden

+46 11 39 31 00 | sales@stafsjo.se | www.stafsjo.com

A Bröer Group Company