

Maintenance instruction

This maintenance instruction is a step-by-step instruction for service and maintenance on Stafsjö TV valve. The instruction shall be available for the persons responsible for service and maintenance on Stafsjö knife gate valves.

The following procedures are described:

- A – Change of seat**
- B – Change of gate and box packing**
- C – Change of box packing when the valve is installed in a system**
- D – Torque for nuts on gland**



For more detailed information on the technical data of the Stafsjö knife gate valves, actuators or accessories, please see data sheets on www.stafsjo.com, or contact Stafsjö Valves AB or your local representative.

Each knife gate valve is identified with the metal plate containing the valve article number and serial number. When corresponding with Stafsjö Valves AB or your local representative, please have these numbers available.

Stafsjö does not accept any responsibility for the product if service and maintenance on the knife gate valve is not performed according to this instruction. Nor does Stafsjö Valves AB accept any responsibility of the product if any significant change has been done to the product.

Spare parts

Recommended spare parts are described in spare part data sheets for each knife gate valve type on www.stafsjo.com. Stafsjö recommends the customer to keep one set of spare parts for each valve type and size in store.

Spare parts can be ordered from Stafsjö Valves AB or your local representative. Spare part data sheets and addresses are available on www.stafsjo.com.

Safety information



No work is allowed on the knife gate valve when the system is pressurised or the actuator is installed. The system must be free from pressure and empty. Actuator and accessories must be disconnected before any work is commenced.

Main components in the Stafsjö knife gate valve TV

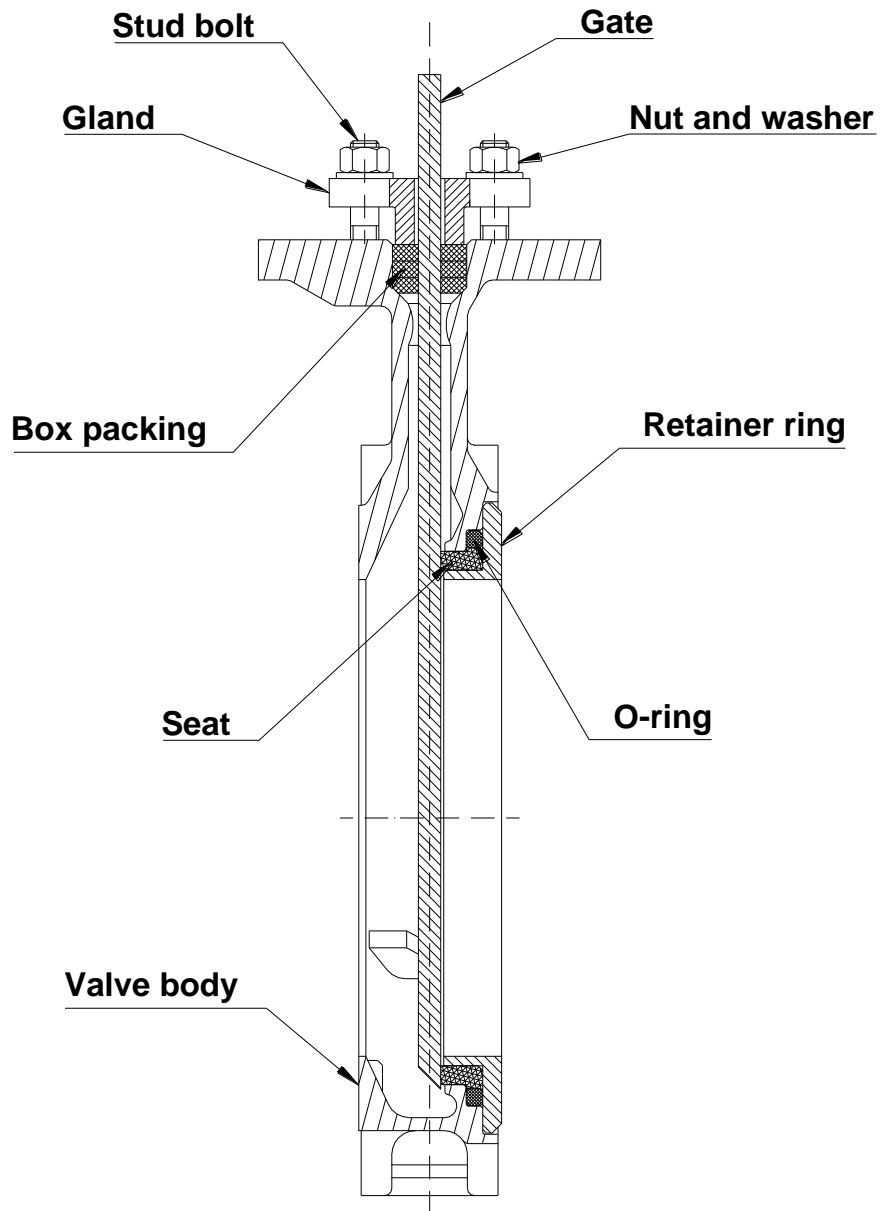

Figure 1

Part list of the Stafsjö knife gate valve TV

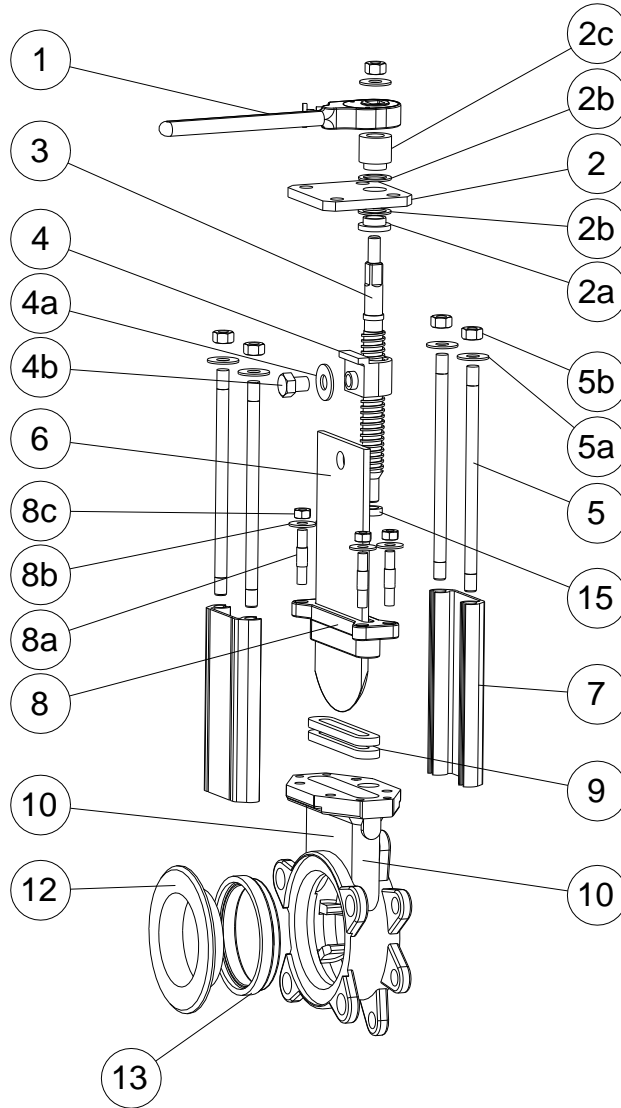

Figure 2

Pos	Part
1	Ratchet wrench
2	Yoke
2a	Bearing
2b	Bearing washer
2c	Bearing
3	Stem
4	Stem nut
4a	Washer

Pos	Part
4b	Screw
5	Tie rod
5a	Washer
5b	Nut
6	Gate
7	Beam
8	Gland
8a	Stud bolt

Pos	Part
8b	Washer
8c	Nut
9	Box packing*
10	Valve body
12	Retainer ring
13	Seat*
15	Bushing

* Recommended spare parts

Service and maintenance

See figure 1 and 2 for identification of the parts in the TV knife gate valve.

For procedures A and B the knife gate valve must not be installed in a system.



No work is allowed on the Stafsjö knife gate valve when the system is pressurized or the automatic actuator is connected. The system must be empty and free from pressure before dismantling of the valve begins. The actuator and accessories must be disconnected.

A - Change of seat

Place the valve horizontally with the seat side up to simplify changing the seat.

1. Close the valve.
2. Loosen the screws the retainer ring (12) is locked with.
3. Lift of the retainer ring (12). If the retainer ring is stuck, use a screw driver or similar and bend carefully between the retainer ring and the valve body in several places around the bore until the retainer ring is loose.
4. Check the gate (6) for damages such as dents and scrapes. If the gate is damaged it can wear out the box packing (9) and the seat (13), causing leakage. Stafsjö recommends changing the gate if it is damaged to ensure the function of the valve.
5. Clean the area for the seat on the retainer ring and the valve body.
6. Install a new seat (13) on the retainer ring and place the retainer ring in the valve body (10). For seat PTFE an o-ring must also be installed. Lubricate the seat and the o-ring with a synthetic lubricator to make the installation easier.
7. Lock the retainer ring (12) with the locking screws. Note! The function of the screws is only to keep the retainer ring in place. The retainer ring function come into force when the valve is installed in a system between pipe flanges.
8. Install the valve in the system according to the operating instruction.
9. Operate the valve a few times before the system is pressurised.

B - Change of gate and box packing

Place the valve upright in for example a screw vice to simplify changing the gate and box packing.

1. Close the valve.
2. Demount the ratchet wrench (1).
3. Loosen the nuts (5b) keeping the yoke (2) in place.
4. Lift off the bearing (2c), bearing washer (2b), yoke (2), bearing washer (2b), bearing (2a) from the stem (3).
5. Demount the beams (7) and tie rods (5).
6. Loosen the screw (4b) from the stem nut (4) and gate (6).
7. Lift off the stem (3) and stem nut (4).
8. Loosen the nuts (8c) on the gland (8).
9. Lift of the gland (8) from the stud bolts (8a).
10. Remove the box packing braids (9).
11. Clean the box from residues.
12. Remove the gate (6) and check it for damages such as dents and scrapes. If the gate is damaged it can wear out the box packing (9) and the seat (13), causing leakage. Stafsjö recommends changing the gate if it is damaged to ensure the function of the valve.
13. Install the gate (6) in the valve body (10). Check that the gate is placed correctly with the gate chamfer on the cams in the bottom of the valve body, see fig. 1.
14. Start the installation of the first braid (9) on one of the long sides of the gate (6). Use a blunt tool in plastic or wood and a hammer to push the braid into the box. Where the braid ends meet, check that the short ends are opposite each other, not on top of each other. It is important to push the first braid evenly into the bottom of the box. The joint of the second braid must be placed on the opposite long side of the joint of the first braid.
15. Place the gland (8) on the stud bolts (8a).
16. Add the washers (8b) and nuts (8c).
17. Put pressure on the gland (8) by tightening the nuts (8c) gradually and crosswise. The box packing must be equally compressed all around. Recommended torque for gland nuts, see chapter D.
18. The gland (8) must put uniform pressure on the box packing (9) and be in level with the top of the valve body (10).
19. The gland (8) must also be in line with the gate (6) with the same distance between the gland and the gate all around. Check that there is no metal contact between the gland (8) and the gate (6).
20. Install the other components in reversed order, steps 7-2.
21. Install the valve in the system according to the operating instruction.
22. Operate the valve a few times before the system is pressurised.

Note:

The box packing may start to leak when the system is pressurised and the temperature increases. This is caused by the box packing which is a soft material that moves depending on pressure and temperature and when the valve is operated. If the box packing is leaking, tighten the gland nuts (8c) gradually and crosswise according to chapter D.

C – Change of box packing when the valve is installed in a system



No work is allowed on the Stafsjö knife gate valve when the system is pressurized or the automatic actuator is connected. The system must be empty and free from pressure before work begins. The actuator and accessories must be disconnected before work begins.

Work on the knife gate valve when the system is under pressure can cause damages on persons and equipment.

Check that the system is free from pressure by:

- Observing the pressure measurement on the system
- Opening the drain on the pipe

When the system is free from pressure and empty:

1. Open the valve making a distance between the gland (8) and the stem nut (4).
2. Loosen the nuts (8c) on the gland (8).
3. Lift the gland (8) and connect it to the stem nut (4) with a wire to be able to reach into the box packing (9).
4. Remove the box packing braids (9).
5. Clean the box from residues.
6. Check the gate (6) visually for damages such as dents and scrapes. If the gate is damaged it can wear out the box packing (9) and the seat (13), causing leakage. Stafsjö recommends changing the gate if it is damaged to ensure the function of the valve.
7. Start the installation of the first braid (9) on one of the long sides of the gate (6). Use a blunt tool in plastic or wood and a hammer to push the braid into the box. Where the braid ends meet, check that the short ends are opposite each other, not on top of each other. It is important to push the first braid evenly into the bottom of the box. The joint of the second braid must be placed on the opposite long side of the joint of the first braid.
8. Let down the gland (8) on the stud bolts (8a).
9. Add the washers (8b) and nuts (8c).
10. Close the valve. Adjust the gate (6) and centre it in the box. Check that the gate chamfer is set against the cams in the bottom of the valve body, see fig. 1.
11. Put pressure on the gland (8) by tightening the nuts (8c) gradually and crosswise. The box packing must be equally compressed all around. Recommended torque for gland nuts, see chapter D.
12. The gland (8) must put uniform pressure on the box packing (9) and be in level with the top of the valve body (10).
13. The gland (8) must also be in line with the gate (6) with the same distance between the gland and the gate all around. Check that there is no metal contact between the gland (8) and the gate (6).
14. Operate the valve a few times before the system is pressurised.

Note:

The box packing may start to leak when the system is pressurised and the temperature increases. This is caused by the box packing which is a soft material that moves depending on pressure and temperature and when the valve is operated. If the box packing is leaking, tighten the gland nuts (8c) gradually and crosswise according to chapter D.

D - Torque for gland nuts

The torque T_G in the table below is a recommended value for tightening the gland nuts (**8c**) when a new box packing has been installed and during operation if the box packing is leaking.

DN	T_G	
	Nm	lbf x ft
50-80	20	15
100-150	25	18
200-300	30	22
350-	35	26

If the gland nuts are pulled to hard, it shortens the lifetime of the box packing and the force needed to operate the valve will increase and the valve function will be affected.

The box packing may leak because it is made of a soft material that moves depending on pressure and temperature and when the valve is operated. If the box packing is leaking, tighten the gland nuts (**8c**). Each nut shall be tightened gradually and crosswise until the leakage stops and the gate moves smoothly without tipping in the opening or closing instant.

Check that the gland (**8**) is level to the top of the valve body (**10**). Check that there is no metal contact between the gland (**8**) and the gate (**6**).

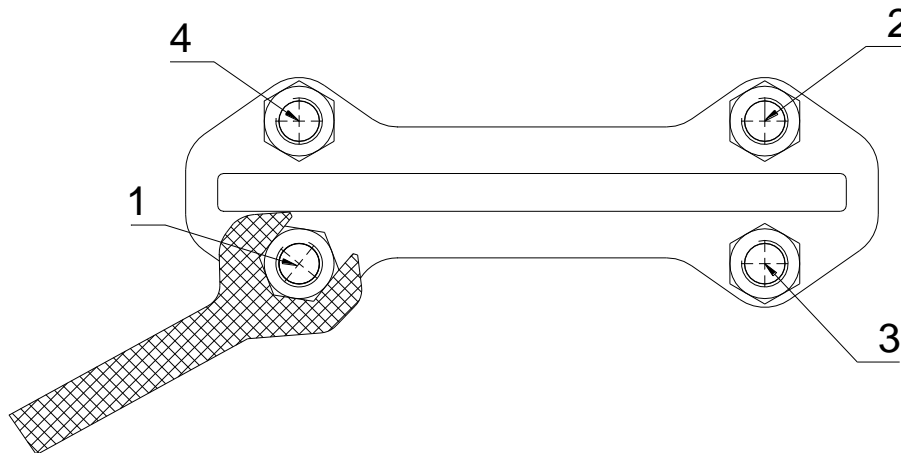

Figure 3: Tighten gland nuts crosswise