

Stafsjö
SINCE 1666

Knife gate valve JTV

The optimal valve solution for junc traps and high density cleaners

Size:
250 x 250 mm (10" x 10")

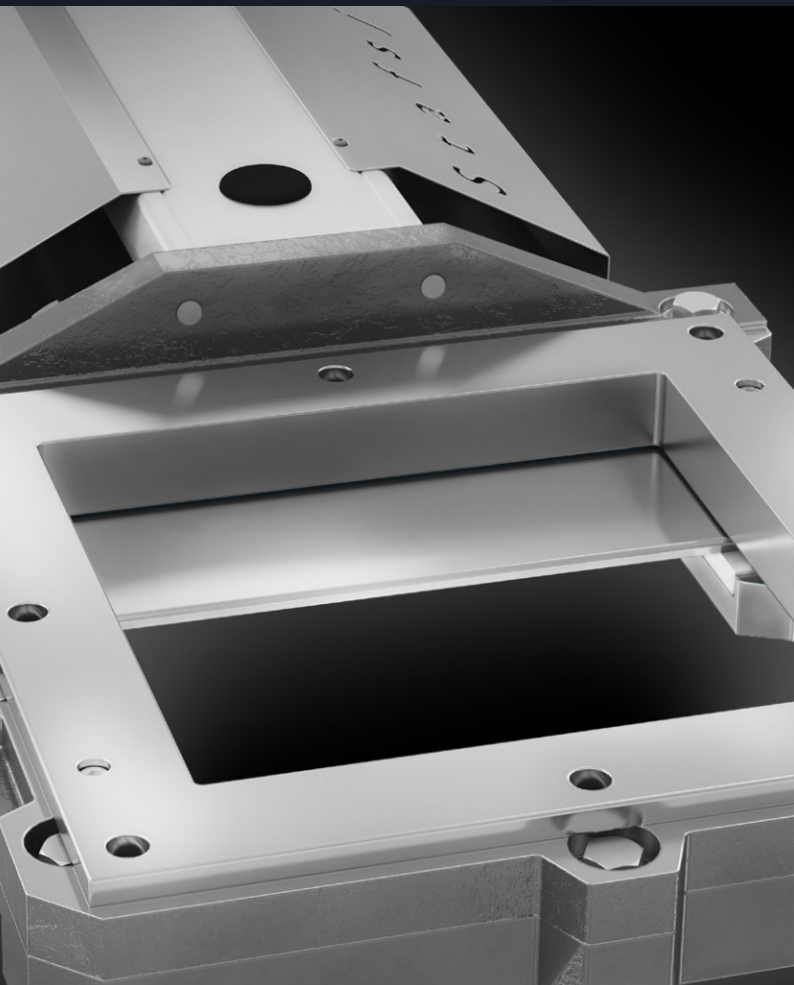

About JTV

This is the optimal valve solution for junc traps and high density cleaners separating abrasive materials such as sand, stones, staples, glass and other type of rejects from the process media.

The JTV knife gate valve is the standard square discharge valve in Stafsjö's Junc Trap solution JT. It is modular designed and can be customized with automation accessories to different process conditions. As standard the JTV knife gate valve is supplied with a precision machined stainless steel valve body and a hard chromed duplex stainless steel gate. The top works is solid to perform during long periods of time in horizontal high cycling applications.



Performance shut-off on severe abrasive reject

The straight bevel edge gate (1) efficiently cut through rejects. The gate supports (2) assure gate guidance throughout the full stroke and support the gate in closed position to maintain a 100 % liquid tight shut-off.

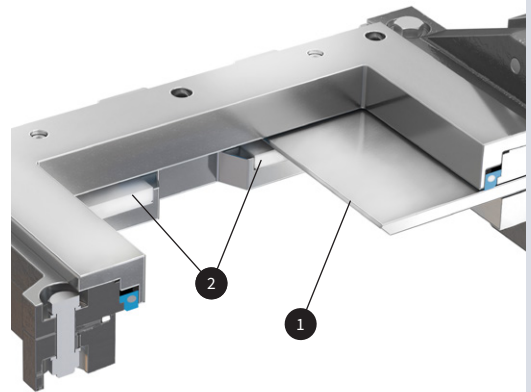

A first rate external sealing

Stafsjö's TwinPack braids (3) perform the main external sealing operation in the system. The gland box is precision machined with tight tolerances to provide optimal room for the TwinPack braids while the gland (4) and position of stud bolts provide a uniform load.



An easy maintenance extend the service life

The JTV is often installed on severe abrasive applications where quick and easy maintenance is important. The retainer ring system (5) allows an easy change of seat (6) and the gate supports (7) can also be switched over to new ones without dismantling the entire valve. This solution ensure low cost of ownership.

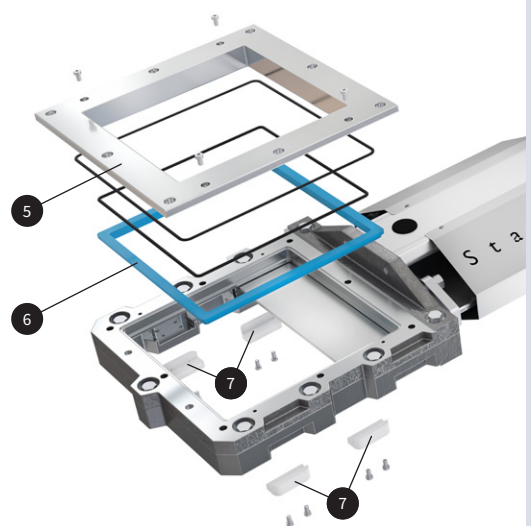

Pressure class

Max working pressure at 20 °C		Max differential pressure at 20 °C	
Size	bar	Size	bar
250 x 250	6	250 x 250	6

Configuration

Standard	Design standards
<p>Sizes: 250 x 250</p> <p>Valve body: Stainless steel EN 1.4408</p> <p>Gate: Hard chromed duplex stainless steel EN 1.4462</p> <p>Retainer ring: Stainless steel EN 1.4408</p> <p>Seat: Polyurethane with o-ring in NBR</p> <p>Box packing: TwinPack</p> <p>Top works: Stainless steel tie rods encapsulated in aluminum beams including stainless steel gate guards</p> <p>Actuator: Double-acting pneumatic cylinder</p> <p>Flange drilling: Stafsjö manufacturing standard</p> <p>See the accessory data sheet for automation options.</p>	<p>Face-to-face dimensions Stafsjö manufacturing standard.</p> <p>Design, manufacturing, inspection and test According to pressure equipment directive 2014/68/EU category I and II module A2. The valves are CE marked when it is applicable.</p> <p>Stafsjö's valves are subject for pressure tests before delivery in opened and closed position with water at 20 °C according to EN 12266-1:2003 rate A. No visually detectable leakage is allowed for duration of the test.</p> <p>On request Stafsjö can provide 2.2 test report and 3.1 inspection certificate according to EN 10204.</p> <p>Contact Stafsjö for further information on ATEX approved solutions.</p> <p>Service temperature Information to determine minimum and maximum temperature for the knife gate valve is available on stafsjo.com/support/service-temperature/.</p>

The optimal solution for high density cleaners

High density cleaners separate sand, stones, staples, glass and other type of reject from the process media. It is often a high cycling application subject to severe wear and vibrations. The Junk Trap (JT) is specially developed to minimize turbulence, erosive wear and build-up of solids and reject material.

Read more about the JT solution of which the JTV knife gate valve is part of at stafsjo.com/products/jt/.

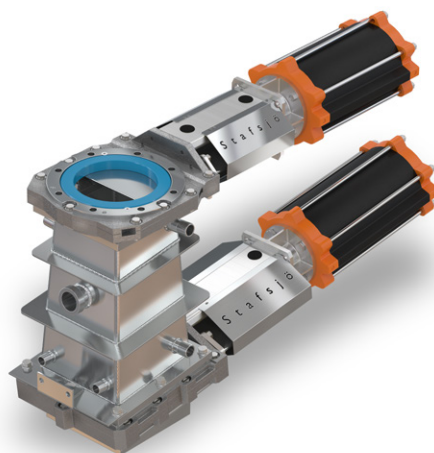

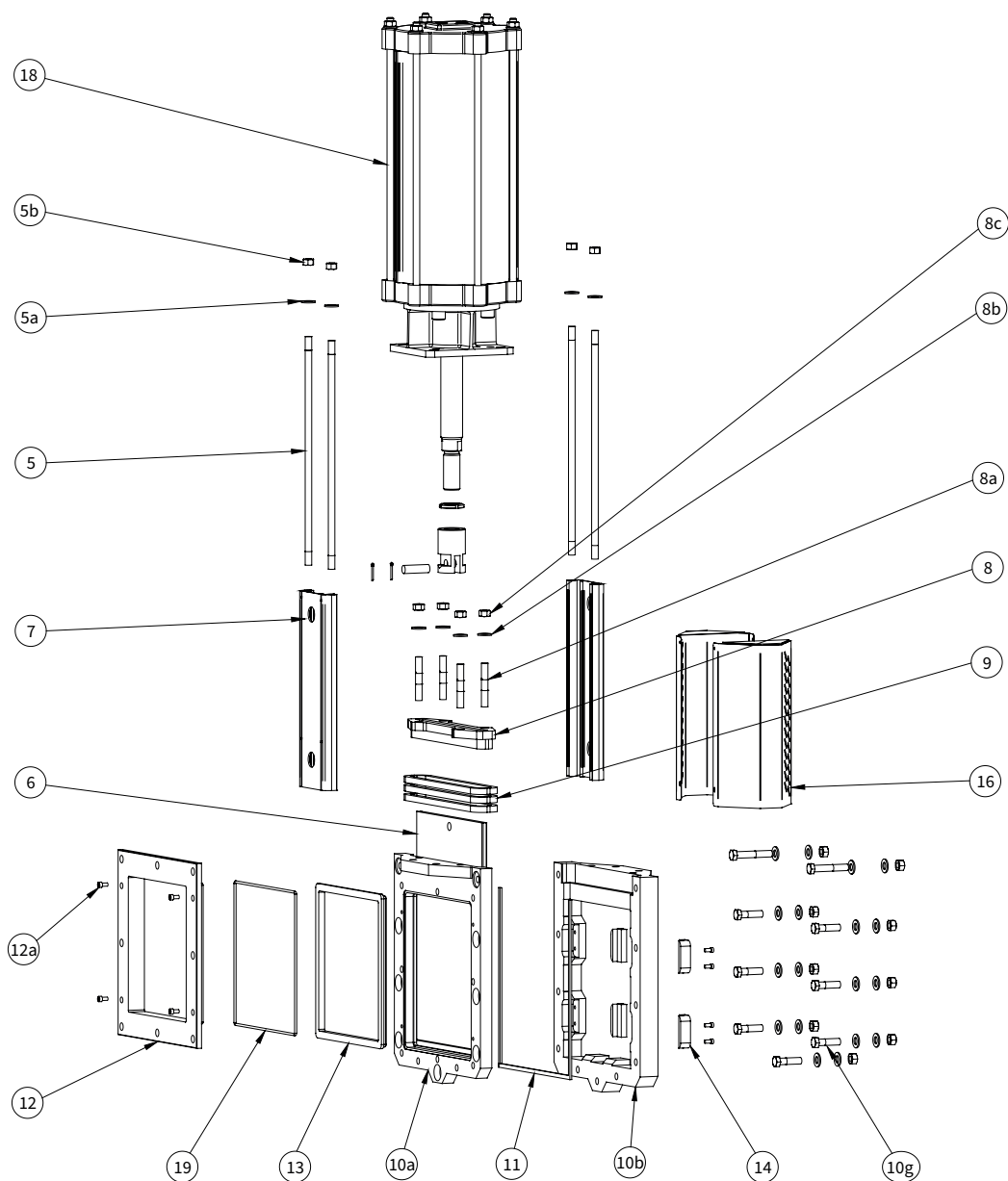

Part list

Pos.	Part	Material
5	Tie rod	Stainless steel A2
5a	Washer	Stainless steel A2
5b	Nut	Stainless steel A2
6	Gate	Hard chromed duplex stainless steel EN 1.4462
7	Beam	Anodized aluminum
8	Gland	Stainless steel EN 1.4408
8a	Stud bolt	Stainless steel A2
8b	Washer	Stainless steel A2
8c	Nut	Stainless steel A2
9 ¹⁾	Box packing	TwinPack

Pos.	Part	Material
10a/b	Valve body	Stainless steel EN 1.4408
10g	Valve body boltings	Stainless steel A2
11	Body gasket	PTFE
12	Retainer ring	Stainless steel EN 1.4408
12a	Locking screw	Stainless steel A2
13 ¹⁾	Seat	Polyurethane
14 ¹⁾	Guiding pads	POM-C
16	Gate guards	Stainless steel EN 1.4301
18	Pneumatic cylinder	See separate data sheet
19 ¹⁾	O-ring	NBR

1) Recommended spare parts

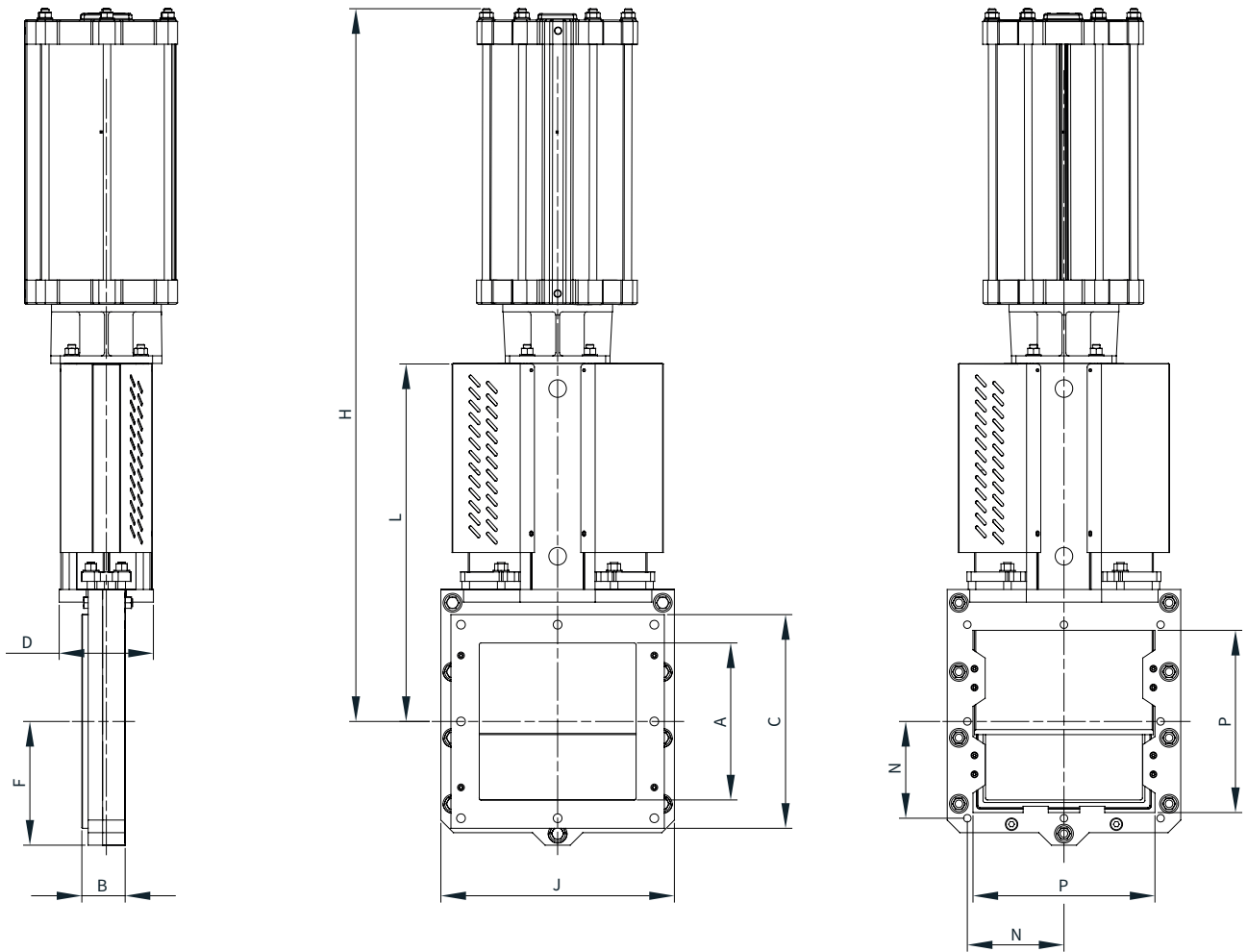

Main dimensions (mm)

Size	A	B	C	D	F	H	J	L	P	kg ¹⁾
250 x 250	250	69	340	152	197	1135	372	570	290	80

Flange drilling Stafsjö standard (mm)

Size	N	Tapped holes	Bolt size	Bolt length
250 x 250	154	8	M12	18 ²⁾
250 x 250	154	8	1/2"-13 UNC	18 ²⁾

1) Weight in kg for valve including double-acting pneumatic cylinder.

2) Add the values with the thickness of the pipe flanges, the washers and thickness of the gasket.

Main dimensions are only for information. Contact Stafsjö for certified drawings.

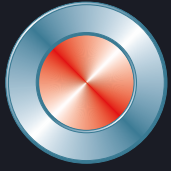

Stafsjö
SINCE 1666

© Stafsjö 2023. Data is only for informational purpose. All specifications are subject to change without notice.

Stafsjö Valves AB
SE-618 95 Stavsjö, Sweden

+46 11 39 31 00 | sales@stafsjo.se | www.stafsjo.com

A Bröer Group Company