

Service instruction for SLV

This service instruction is a step-by-step instruction for service and maintenance on Stafsjö's knife gate valve SLV.

Following procedures are described in this service instruction:

- A. Change of seat**
- B. Change of gate and box packing**
- C. Change of box packing when the valve is installed in a system**
- D. Torque for nuts on gland**
- E. Change from hand wheel (HW) to pneumatic cylinder (AC) when the valve is installed in a system**



For procedures A and B the knife gate valve must be uninstalled from the system.

For information on installation and operation procedures or detailed technical data, please see documents available on www.stafsjo.com.

Each knife gate valve is identified with a label containing the article number and serial number. When corresponding with Stafsjö or your local representative, please have these numbers available.

Stafsjö does not accept any responsibility for the product if service and maintenance on the knife gate valve is not performed according to this instruction. Neither does Stafsjö accept any responsibility for the product if it has been modified from its original condition.

Spare parts

Stafsjö recommends the customer to keep one set of spare parts for each valve type and size in store.

Spare parts can be ordered from Stafsjö or your local representative. Stafsjö also offers service and maintenance of the valve, either in the customer's plant or at Stafsjö workshop. Please contact Stafsjö or your local representative for more information.

Safety information



No work is allowed on the knife gate valve when the system is pressurised or the actuator is connected. The system must be free from pressure and empty. Actuator and accessories must be disconnected before any work begins.

All gate guards must be installed on the valve after maintenance.

Main components of Stafsjö's SLV

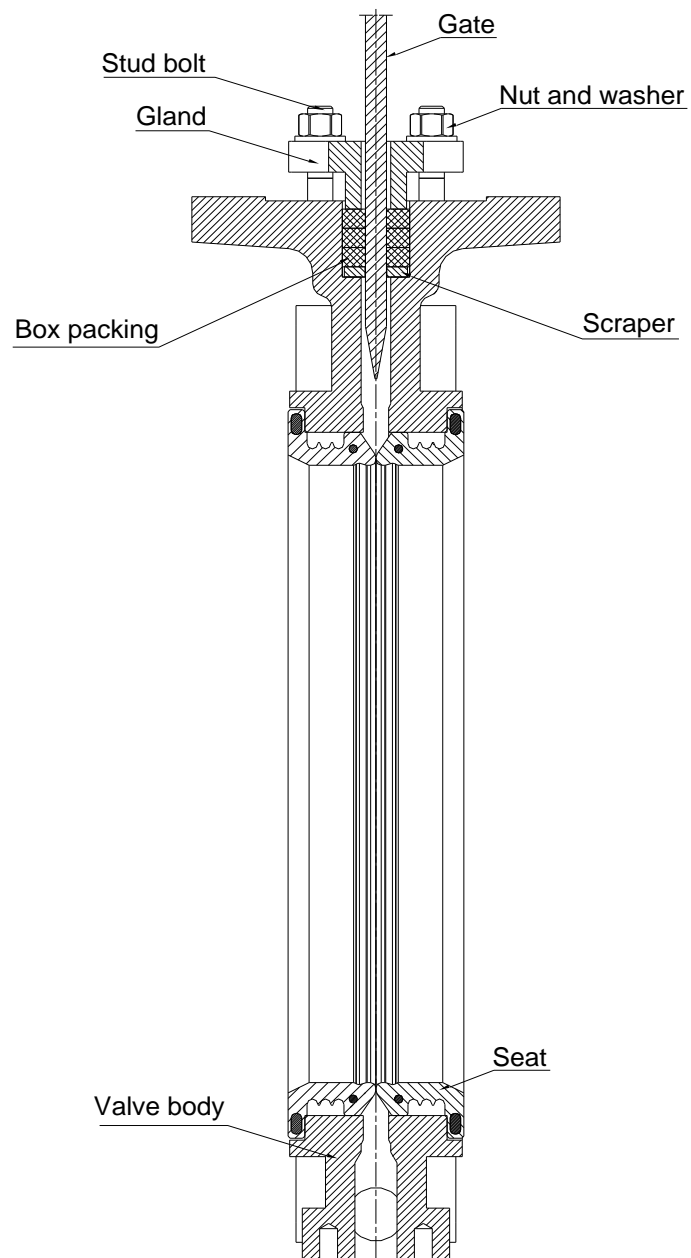

Part list of Stafsjö's SLV (Figure 2)

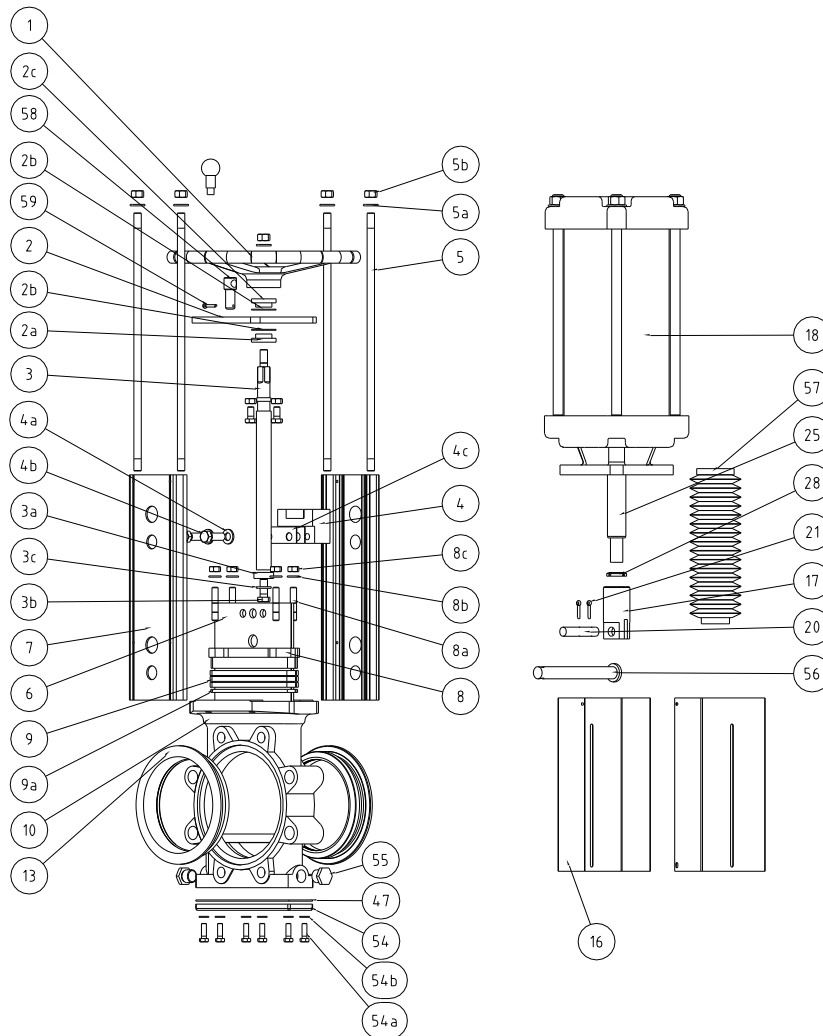

Pos.	Detail	Pos.	Detail	Pos.	Detail	Pos.	Detail
1	Hand wheel	4b	Screw	9	Box packing	47	Gasket
2	Yoke	4c	Distance plate	9a	Box bottom scraper	54	Bottom lid
2a	Bearing	5	Tie rod	10	Valve body	54a	Screw
2b	Slide washer	5a	Washer	13	Seat	54b	Washer
2c	Bearing	5b	Nut	16	Gate guard	55	Plug
3	Stem	6	Gate	17	Gate clevis	56	Locking pin
3a	Stop washer	7	Beam	18	Cylinder	57	Bellow
3b	Screw	8	Gland	20	Clevis pin	58	Locking pin for HW
3c	Washer	8a	Stud bolt	21	Split pin	59	Split pin
4	Stem nut	8b	Washer	25	Piston rod		
4a	Washer	8c	Nut	28	Locking nut		

A. Change of seat

Place the valve horizontally for simple change of seats.

1. Open the valve.
2. Remove the seat (**13**).
3. Check the gate (**6**) for damages such as dents and scratches. If the gate is damaged it can wear out the box packing (**9**) and the seat (**13**), which could cause leakage. Stafsjö recommends changing the gate if it is damaged to ensure the proper operation of the valve.
4. Clean the area of the seat and the valve body.
5. Lubricate the seats with grease, OKS1110 or similar.
6. Place the new seats (**13**) in the bore of the valve body (**10**).
7. Install the valve in open position into the system. See operating instruction for further information.
8. Operate the valve a few times before the system is pressurised.

B. Change of gate and box packing

Place the valve upright, in for example a screw vice, for simple change of the gate and box packing. Large valves should be placed horizontally on a work bench.

1. Close the valve completely.
2. Demount the actuator and top.

- Hand wheel (**1**)
- a. Demount the hand wheel (**1**).
 - b. Loosen the nuts (**5b**).
 - c. Lift off the bearing (**2c**), bearing washer (**2b**), yoke (**2**), bearing washer (**2b**) and bearing (**2a**) from the stem (**3**).
 - d. Demount the beams (**7**) and tie rods (**5**).
 - e. Loosen the screw (**4b**) from the stem nut (**4**) and gate (**6**).
 - f. Lift off the stem (**3**) and stem nut (**4**).

- Pneumatic cylinder (**18**)
- a. Loosen the gate guards (**16**).
 - b. Demount the split pins (**21**) and the clevis pin (**20**).
 - c. Loosen the nuts (**5b**) keeping the cylinder in place.
 - d. Lift off the cylinder (**18**).
 - e. Remove the beam (**7**) and tie rods (**5**) from the valve.

3. Loosen the nuts (**8c**) on the gland (**8**).
4. Lift of the gland (**8**) from the stud bolts (**8a**).
5. Remove the box packing braids (**9**) and the box bottom scraper (**9a**).
6. Clean the box from residues.
7. Remove the gate (**6**).
8. Remove the seats (**13**). The procedure is described in section A.
9. Remove the plugs (**55**)
10. Use a plastic or wooden round bar and put into the purge ports to make a stop for the gate, see picture 3.
11. Place the new gate (**6**) into the valve body.
12. Place the box bottom scraper (**9a**) in the bottom of the gland box. Install the first braid (**9**) on one of the long sides of the gate (**6**). Use a blunt tool in plastic or wood and a hammer to push the braid into the box. Make sure that the braid ends meets properly. It is important to push the first braid evenly into the bottom of the box. The joint of the second and third braid must be placed on the opposite long side of the joint of the previous braid, not on top of each other.

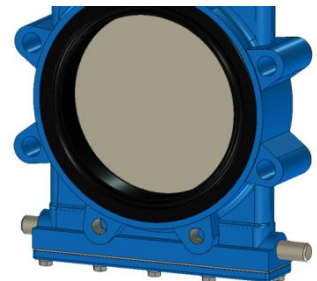

Picture 3

13. Install the gland **(8)** on the stud bolts **(8a)**.
14. Add washers **(8b)** and nuts **(8c)**.
15. Install the seats **(13)**, see section A.
16. Put pressure on the gland **(8)** by tightening the nuts **(8c)** gradually and crosswise, see figure 4. The box packing must be equally compressed all around. Recommended torque for gland nuts, see section D.
17. The gland **(8)** must put a uniform pressure on the box packing **(9)**. The gland **(8)** must also be in line with the gate **(6)** with the same distance between the gland and the gate all around. Check that there is no metal contact between the gland **(8)** and the gate **(6)**.
18. Remove the round bar from the purge ports and install the plugs **(55)**.
19. Install the other components in reversed order according to step 2.
20. Make a function test before the valve is put into operation.
21. Make sure that the valve is fully open.
22. Install the valve in the system according to instructions in the operating instruction.
23. Operate the valve a few times before the system is pressurised.

Note:

The box packing may start to leak when the system is pressurised and the temperature increases. This is caused due to that the box packing, which is a soft material, moves depending on pressure and temperature when the valve is operated. If the box packing is leaking, tighten the gland nuts **(8c)** gradually and crosswise according to chapter D.

C – Change of box packing when the valve is installed in a system



No work is allowed on the Stafsjö knife gate valve when the system is pressurised or the automatic actuator is connected. The system must be empty and free from pressure before any work begins and the actuator and accessories must be disconnected.

Work on the knife gate valve when the system is under pressure can cause damages on persons and equipment.

Check that the system is free from pressure by:

- **Observing the pressure measurement on the system**
- **Opening the drain on the pipe**

When the system is free from pressure and empty:

1. Check the gate **(6)** visually for damages such as dents and scratches. If the gate is damaged it can wear out the box packing **(9)** and the seats **(13)**, which could cause leakage. Stafsjö recommends changing gate if it is damaged in order to ensure proper operation. Procedure of changing the gate is described in section B.
2. Close the valve completely.
3. Demount the actuator and top.

- | | |
|-----------------------|--|
| Hand wheel (1) | g. Demount the hand wheel (1) . |
| | h. Loosen the nuts (5b) . |
| | i. Lift off the bearing (2c) , bearing washer (2b) , yoke (2) , bearing washer (2b) and bearing (2a) from the stem (3) . |
| | j. Demount the beams (7) and tie rods (5) . |
| | k. Loosen the screw (4b) from the stem nut (4) and gate (6) . |
| | l. Lift off the stem (3) and stem nut (4) . |

- Pneumatic cylinder (18)
- f. Loosen the gate guards (16).
 - g. Demount the split pins (21) and the clevis pin (20).
 - h. Loosen the nuts (5b) keeping the cylinder in place.
 - i. Lift off the cylinder (18).
 - j. Demount the beam (7) and tie rods (5) from the valve.

4. Loosen the nuts (8c) on the gland (8).
5. Lift off the gland (8) from the stud bolts (8a).
6. Remove the box packing braids (9) and the box bottom scraper (9a).
7. Clean the box from residues.
8. Push down the box bottom scraper (9a) into the bottom of the gland box. Install the first braid (9) on one of the long sides of the gate (6). Use a blunt tool in plastic or wood and a hammer to push the braid into the box. Make sure that the braid ends meet properly. It is important to push the first braid evenly into the bottom of the box. The joint of the second and third braid must be placed on the opposite long side of the joint of the previous braid, not on top of each other.
9. Place the gland (8) on the stud bolts (8a).
10. Add the washers (8b) and nuts (8c).
11. Put pressure on the gland (8) by tightening the nuts (8c) gradually and crosswise, see figure 4. The box packing must be equally compressed all around. Recommended torque for gland nuts, see chapter D.
12. The gland (8) must put a uniform pressure on the box packing (9). The gland (8) must also be in line with the gate (6) with the same distance between the gland and the gate all around. Check that there is no metal contact between the gland (8) and the gate (6).
13. Operate the valve a few times before the system is pressurised.

Note:

The box packing may start to leak when the system is pressurised and the temperature increases. This is caused due to that by the box packing, which is a soft material, moves depending on pressure and temperature and when the valve is operated. If the box packing is leaking, tighten the gland nuts (8c) gradually and crosswise according to chapter D.

D - Torque for gland nuts

The torque T_G in the table below is a recommended value for tightening the gland nuts (8c).

If the box packing is leaking, tighten the gland nuts (8c).

Each nut shall be tightened gradually and crosswise until the leakage stops and the gate moves smoothly without tipping in the opening or closing instant.

DN	TG	
	Nm	lbf x ft
50 – 80	25	18
100 – 150	30	22
200 - 600	35	26

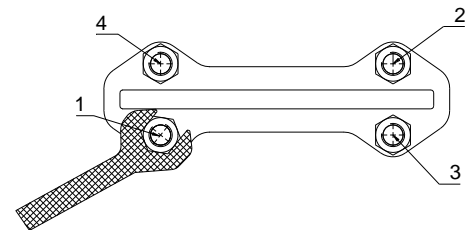

Figure 4: Tighten gland nuts crosswise

If the gland nuts are tightened to hard, it shortens the lifetime of the box packing and increases the force needed to operate the valve.

Check that the gland (8) is in level to the top of the valve body (10). Check that there is no metal contact between the gland (8) and the gate (6).

E – Change from hand wheel (HW) to pneumatic cylinder (AC) when the valve is installed in a system



No work is allowed on the Stafsjö knife gate valve when the system is pressurised or the automatic actuator is connected. The system must be empty and free from pressure before any work begins and the actuator and accessories must be disconnected.

Work on the knife gate valve when the system is under pressure can cause damages on persons and equipment. Check that the system is free from pressure by:

- Observing the pressure measurement on the system
- Opening the drain on the pipe

Before installing a pneumatic cylinder onto the valve, you must always check:

- That the pneumatic cylinder is correct in size regarding the size SLV valve.
- That the air supply to the cylinder is correct regarding, quality, pressure and flow.

1. Close the valve completely.
2. Demount the hand wheel, see section B: 2.
3. Screw the locking nut (28) and the gate clevis (17) halfway up on the threaded part of the piston rod (25).
4. Mount the cylinder (18) on top of the beams and fixate it with washers (5a) and nuts (5b). Make sure you have necessary support for the pneumatic cylinder.
5. Attach the gate clevis (17) to the gate with clevis pin (20) and the split pins (21).
6. Open the valve completely by gently operating the pneumatic cylinder (18). In this position, the clevis pin should be in centre of the upper limit switch hole in the beam (7), see picture 5. If it is not, close the valve and demount the split pins (21) and clevis pin (20). Adjust the gate clevis (17) on the piston rod (25) until it is in the centre of the upper limit switch hole in the beam when the valve is completely open.
7. Lock the gate clevis (17) with the locking nut (28).
8. Mount the gate guards (16).
9. Before the actuation test are carried out make sure:
 - The pneumatic cylinder is correctly mounted on the knife gate valve with adjusted cylinder stroke.
 - The air connected to the cylinder does not exceed maximum allowed pressure of 10 bar.
 - The air pipe connected to the cylinder has the right size and is correctly installed.
 - The knife gate valve and pneumatic cylinder have sufficient supported to avoid tensions.
10. Operate the valve a few times before the system is pressurised.

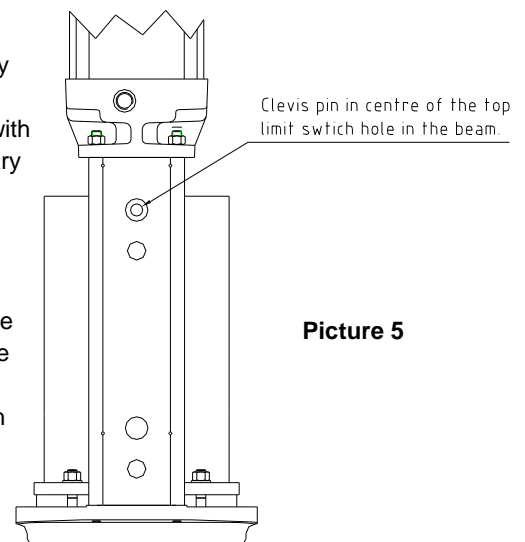

Picture 5